

## THE SHEET METAL FORMING WITH HYDRAULIC FLUID PRESSURE

Received - Primljeno: 2003-12-24

Accepted - Prihvaćeno: 2004-07-20

*Preliminary Note - Prethodno priopćenje*

The plastic forming of sheet metal with fluid pressure has most application at the modern producing of special elements and element of widespread use. Higher relations of drawing ratio are reached by the application of this technology and it is decreased the number of necessary operations and tools as well as the decreasing of costs to product unit. The quality of produced products is considerable better than classic methods therefore there are satisfactory tribological conditions of plastic forming. Therefore there is considerable application increasing of this technology at the technological developed countries.

**Key words:** *deformation, fluid forming, stress state, forming force*

**Plastično oblikovanje lima nestišljivim fluidom.** Plastično oblikovanje pomoću nestišljivog fluida ima sve veću primjenu u modernoj proizvodnji specijalnih elemenata i elemenata široke potrošnje. Primjenom ove tehnologije postižu se veći odnosi izvlačenja, smanjuje se broj potrebnih operacija i alata, te se smanjuju troškovi izrade po jedinici proizvoda. Kvaliteta dobivenih proizvoda je znatno bolja u odnosu na klasične metode jer su bolji tribološki uvjeti plastičnog oblikovanja. Zbog toga je značajan porast primjene ove tehnologije u tehnološki razvijenim zemljama.

**Ključne riječi:** *deformacija, oblikovanje fluidom, napregnuto stanje, sila prerade*

### INTRODUCTION

Fluid metal forming is unconventional procedure of plastic forming where the fluid is working media as means of drawing by additive abilities versus corrosion and foaming. The fluid application at the procedures of drawing is by processing procedures of deep-drawing, tube forming, binding, hydrostatic processing (extrusion).

The processing with unpressed fluid gives the good quality of surface processing, the procedure isn't to much required, the hard tool is simpler without material lose and it has possibility of height automatization procedure processing, etc.

It is made forming by fluid the complex elements of flat sheet metal, tubes and the other spaced elements [1 - 7]. In the last ten years increases application of hydroforming at the car industry, processing industry and metal industry, aircraft industry and military equipment.

---

M. Jurković, Technical Faculty University of Rijeka, Rijeka, Croatia, I. Mamuzić, Faculty of Metallurgy University of Zagreb, Sisak, Croatia, E. Karabegović, Faculty of Technical Engineering University of Bihać, Bihać, Bosnia and Herzegovina

### THE PROCEDURES OF ELEMENT DRAWING FROM SHEET METAL

The deep drawing of elements from sheet metal has four classes of procedures (Figure 1.):

- I. Class-Forming and forming force carrier is the hard tool (punch).
- II. Class-The measuring, forming carrier of work piece is hard plate (die) and the forming force is made by fluid or elastic environment acting.
- III. Class-The measuring, forming carrier is the hard tool since the forming force stressed by element is made by fluid or elastic environment.
- IV. Class-Workpiece geometry is formed by unpressed fluid that is carrier of forming force.

The given examples in this paper present drawing that is made at the hard die by acting fluid on the sheet metal, that fits to II class of procedures. Fluid take the role of extractor as forming force carrier, since the form carrier is hard die.

It can be produced by this of procedures the different forms as: cylindrical, conical, spherical, elliptical, unsymmetrical as well as hydroforming part at the surface where

the thickness of sheet metal is constant if is ignored through forming process.

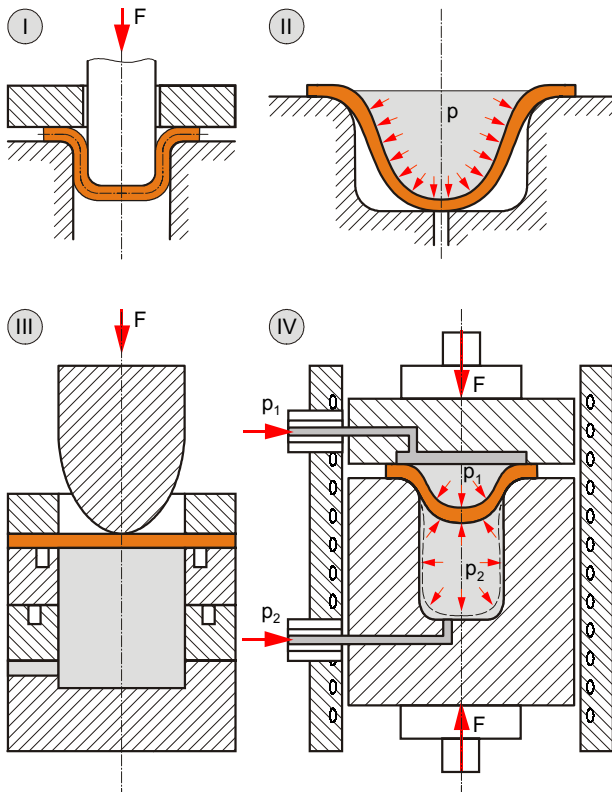

Figure 1. Classification of sheet metal forming procedures  
Slika 1. Klase postupaka plastičnog oblikovanja lima

**THE THEORETICAL ANALYSE OF HYDROFORMING PROCESS**

The forming of sheet metal can be made by fluid with and without blankholder [1, 2, 7].

**Drawing of cylindrical elements without blankholder**

The procedure of drawing of sheet metal with unpressed fluid without blankholder id developed at three phases, as shown at Figure 2a.

*The first phase* - drawing of sheet metal, where are freely stressed the sheet metal at the central part under acting of unpressed fluid.

*The second phase* - drawing where is increased the height of stressed part to die high, and there is binding radius at the meridian cross sectional are unchanged standing, and at the die peak is formed cylindrical part, where is coming to sheet metal flatten.

*The third phase* - drawing fits to element forming to die form.

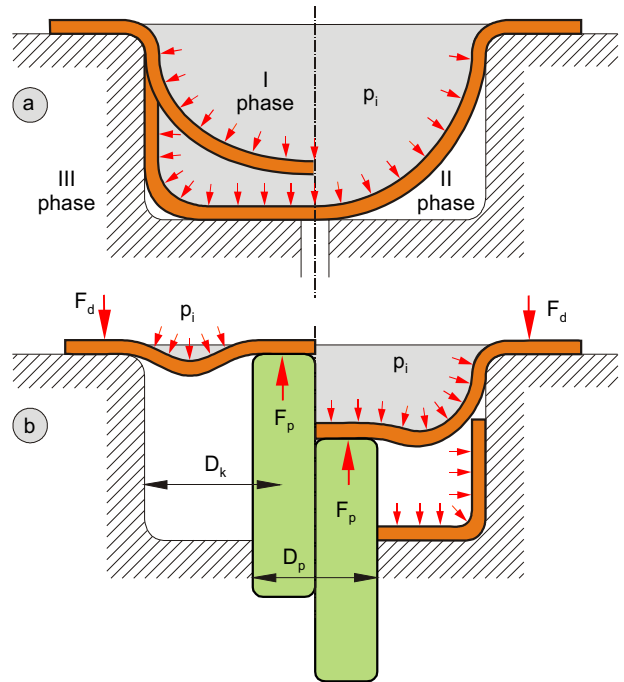

Figure 2. The drawing phase of sheet metal elements by means of fluid without blankholder (a) and with blankholder (b)  
Slika 2. Faze izvlačenja elemenata od lima fluidom bez (a) i sa pridrživačem (b)

**Drawing of cylindrical parts with blankholder**

*An analyse of stress - strain state at the conical element drawing*

At the central part of element occurs flatted stressing state at the drawing with unpressed fluid. Because that is considerable decreasing of wall thickness of sheet metal at this part specially at the peak of spherical part where is the most loaded workpiece. At the increased resistance or

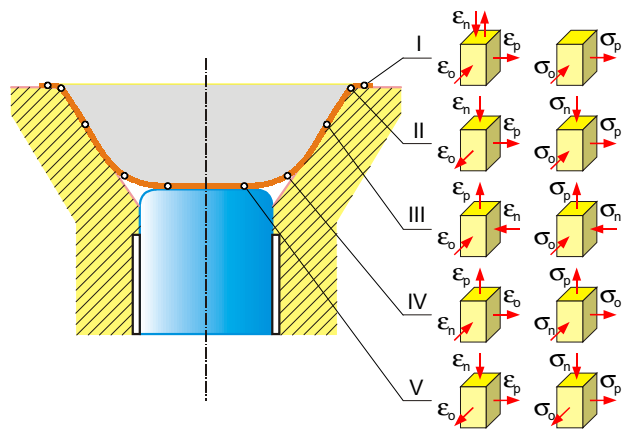

Figure 3. Stress and strain at the conical element by fluid drawing  
Slika 3. Naprezanja i deformacije pri izvlačenju fluidom konusnih elemenata

at the bigger outside diameter or at the worse lubricating increases stress resistance since friction resistance increases that the classical drawing what can cause cutting or sheet metal at the peak part of spherical part.

For an analyse of stressing state at the drawing of conical products with unpressed fluid without thickness decreasing is viewed at some moment of drawing. In this moment the viewed part can be divided into five parts at which are occurred the different schemes of stress and strain as shown at the Figure 3. The parts I, II and III are the same as well as at the classical forming.

**An analyse of stress-strain state at the cylindrical element drawing**

An analyse of stress-strain state at the cylindrical element drawing from sheet metal with application of moving punch is given at the Figure 4.

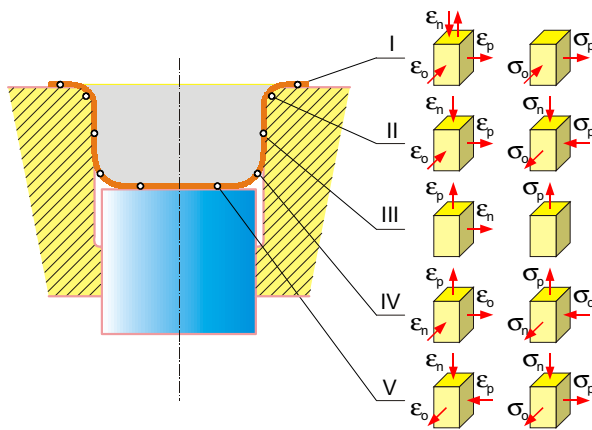

Figure 4. Drawing schema of stress - strain by cylindrical elements  
Slika 4. Shema naprezanja i deformacija pri izvlačenju cilindričnih elemenata

Drawing of cylindrical elements at the second class is shown at the Figure 5.

Blankholder force  $F_p$ :

For  $F_p = 0$ , drawing is without blankholder.

For  $F_p > p_i \cdot A_p$ , it can be happened cutting at the outside drawing of blankholder ( $D_p$ ).

For  $0 < F_p < p_i \cdot A_p$ , happening of blankholder moving which is of the second class with application of moving blankholder where are:

$p_i$  - fluid pressure of drawing,

$A_p$  - surface of holder plate front,  $A_p = \frac{D_p^2}{4} \pi$ ,

$D_p$  - holder plate diameter,

$D_k$  - die diameter.

The most often is  $D_p = D_k$  or  $D_p = D_k - 2r$ .

The analyse up giltys for:  $0 \leq D_p < D_k$ . For  $D_p = 0$  procedure is transformed into drawing without blankholder.

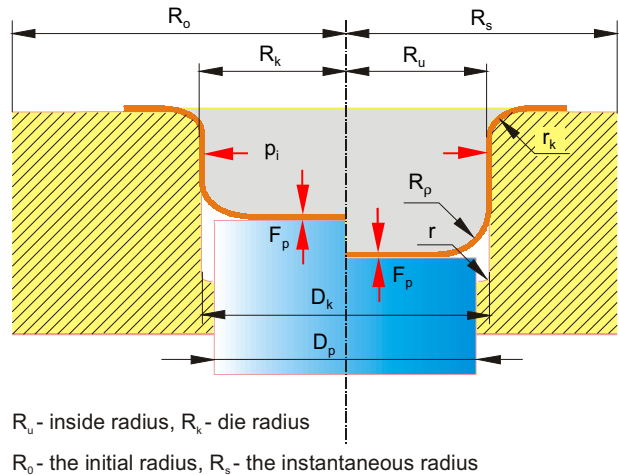

$R_u$  - inside radius,  $R_k$  - die radius  
 $R_0$  - the initial radius,  $R_s$  - the instantaneous radius

Figure 5. Drawing of cylindrical elements at the second class  
Slika 5. Izvlačenje cilindričnih elemenata po drugoj klasi

For the second class with application of moving blankholder, but for case of  $D_p = D_k$  is needed to fill a condition of:

$$F_p \leq p_i \cdot A_p \tag{1}$$

In this case of deformation preventing of sheet metal at the central part of element that means that sheet metal must be flat at the radius of front blankholder  $D_p$  is needed that the force  $F_p$  increases at the defined law. The maximum force  $F_p$  will be cycled bottom at the smallest radius  $R_p$  (Figure 5.), when will beat the reaching of flat surface of diameter  $d$  is needed to be the blankholder force:

$$F_p = \beta \cdot k \cdot \frac{\pi \cdot s}{2R_k} d^2 \tag{2}$$

where:

$d$  - diameter of flat element part at the blankholder front,

$k$  - deformation (yield stress),

$s$  - sheet metal thickness,

$\beta = 1,1$  to  $1,155$  - coefficient of flatted strained state.

Along the knowing of force  $F_p$  of moving blankholder of sheet metal at the drawing of cylindrical elements of the second class of drawing is needed to know the fluid pressure change during drawing processing what is produced by the ground of an state analyse of stress with application of balance equation and plastic conditions [4].

Fluid pressure needed for drawing at the second class is produced from balance force condition which are against to forming and forces defined by material hardness that means:

$$p_i = \frac{2R_u \cdot s}{K_s \cdot R_k^2} \cdot \sigma_1 + \frac{F_p}{\pi \cdot R_k^2} \quad (3)$$

where:

$K_s = 0,9$  – security coefficient,  
 $\sigma_1$  - radial stress at the cylindrical part of element.

The expression (3) defines the law of change of fluid pressure since the blankholder moves into its end position for what must we know radial stress  $\sigma_1$ . At the drawing of cylindrical elements from flat preparing part, can be taken the first maximum of pressure at some enough small friction coefficient  $\mu$  as at classical drawing (with hard tools) that means:

$$p_{1max} = \frac{2R_u \cdot s}{K_s \cdot R_k^2} \left( \beta \cdot k \cdot \ln \frac{R_s}{R_u} + \frac{\mu \cdot F_d}{\pi \cdot R_s \cdot s} + \beta \cdot k \frac{s}{2r_k + s} \right) \cdot (1 + 1,6\mu) + \frac{F_p}{\pi \cdot R_k^2} \quad (4)$$

where is:

$$(1 + 1,6\mu) = e^{\frac{\mu \cdot \pi}{2}}$$

The pressure (4) decreases further at the drawing, since the holder moves into its end position that means that cylindrical element isn't pulled with cyclic  $R_p$  at the element bottom.

For case where we wish to get  $R_p$  smaller than obtained value so that is needed to make pressure increasing (it comes to sheet metal lengthen at the radius part  $R_p$ ) to law of:

$$p_i = \frac{2R_u \cdot s \cdot k}{K_s \cdot R_p (2R_k - R_p)} \quad (5)$$

where:

$R_p$  - searched radius of cyclic at the element bottom,  
 $k$  - specific stressed resistance where is taken  $k = k_0$ .

Decreasing of radius  $R_p$  increases  $p_i$  overtake value of  $p_0$  at expression (4) which can cause thinness of sheet metal at the radius part  $R_p$ , and that is minimum of  $R_p$  bordered on condition to not to come to cutting.

### Drawing of T-shape product

Analysing stress - stain state is estimated four characteristic zones (Figure 6.) [2 - 4]:

- I - zone of the main tube (flatted stress - state),
- II - zone of tube translating into drainage (volume stress - stain state),
- III - drainage zone (stress state of pressure and stretching),
- IV - drainage peak zone (stress of pressure and stretching).

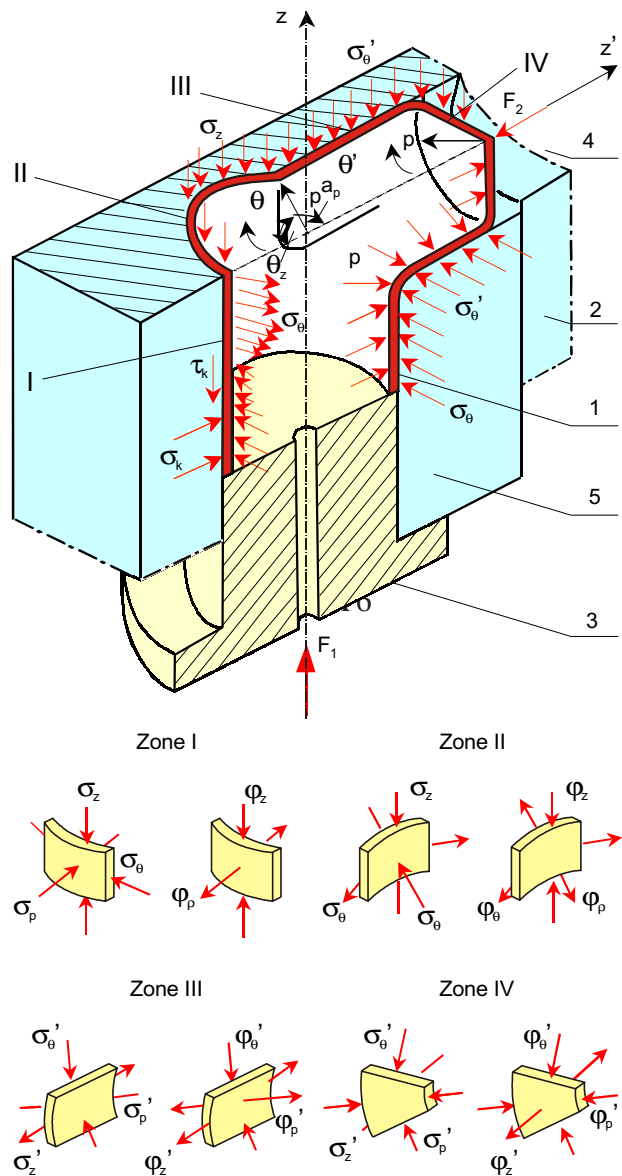

Figure 6. Stress - strain scheme of state T-shape product  
 Slika 6. Shema napregnutog i deformacijskog stanja T - račve

The stresses I and II can be defined mathematically, the stresses III and IV can be determined only certainly therefore different actions of moving ends and axial presses.

Fluid pressure inside of formed tube determines by means of expression in the form of:

$$p = \frac{\beta \cdot k \cdot s \left( \frac{1 - \frac{R_0}{\rho}}{R_\rho} + \frac{1}{R_\theta} \right) - \frac{s \cdot R_0 \cdot F_A}{R_\rho \cdot \rho \cdot A}}{1 + \frac{s}{R_\rho} \left( 1 + \frac{R_\rho}{\rho} \right) + \frac{s}{R_\theta}} \quad (6)$$

where:

- $s$  (mm) - tube thickness,
- $R_0$  (mm) - the middle radius of tube,  $R_0 = \frac{d - s_0}{2}$ ,
- $R_\rho$  (mm) - radius of free bending,
- $R_\theta$  (mm) - radius,  $R_\theta = \frac{\rho}{\cos \alpha_i}$ ,
- $F_A$  (N) - axial force,
- $\alpha_i$  - angle of scope of tube about profile ring,
- $A$  (mm<sup>2</sup>) - tube cross sectional area,  $A = \frac{\pi}{4}(d^2 - d_u^2)$ ,
- $\rho$  (mm) - bending radius,  $\rho \geq R_0$ ,
- $d, d_u$  (mm) - inside and outside tube cross sectional area.

With increasing of the force  $F_A$  to expression (6), there is decreased the value of fluid pressure needed for tube forming. Mathematical viewed it has the value of the force  $F_A$  where is  $p = 0$ , that means that helping axial force  $F_A$  can be formed tube without pressure acted fluid. That isn't fully enabled therefore the tube will be irregular formed because of stability lose of tube sheet metal. The fluid pressure ( $p$ ) increases with tube thickness increasing and material hardness ( $k$ ).

If during the forming process the pressure  $p = \text{const.}$  and for the beginning value:

$$R_0 = \rho; R_\rho = \infty; R_\theta = \frac{\rho}{\cos \theta} = R_0,$$

expression (6) for pressure gets the form of:

$$p = \beta \cdot k \frac{s}{R_0 + s} \quad (7)$$

Axial force:

$$F_A = F_{pd} + F_{pf} \quad (8)$$

where are:

- $F_{pd}$  (N) - force for plastic forming of tube material,
- $F_{pf}$  (N) - force for pressure fluid in tube acted by presses,

$$F_{pd} = \frac{\pi}{4} (d^2 - d_u^2) \left( \frac{\beta \cdot k}{2} - p \right)$$

$$F_{pf} = p \frac{\pi \cdot d_u^2}{4} \quad (9)$$

Changing values  $F_{pd}$  and  $F_{pf}$  at the expression (8) is produced expression for axial force:

$$F_A = \frac{\pi}{4} \left[ \left( \frac{\beta \cdot k}{2} - p \right) (d^2 - d_u^2) + p \cdot d_u^2 \right] \quad (10)$$

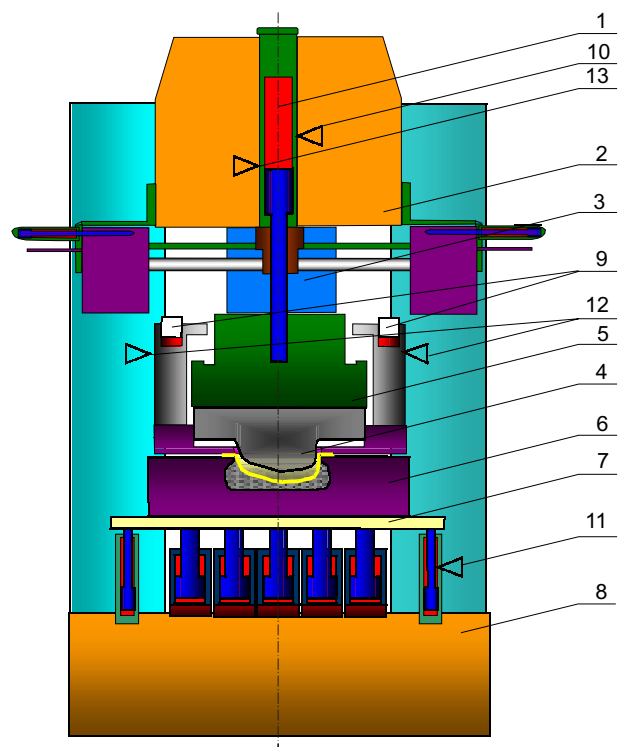

1. Force cylinder of tool holder
2. The upper ram
3. The tool holder (5)
4. Holder during drawing process
5. The upper tool (die)
6. The down tool (deformation fluid force)
7. Cylinder for tool closing (5) and (6)
8. The down presses carrier
9. Cylinders needed for sheet metal blankholder force
10. Sensors of holder pressure (4) at the cylinder (1)
11. Sensor of force pressure of forming at the cylinder (7)
12. Sensors of blankholder pressure of sheet metal at the cylinder (9)
13. Sensors for travel measuring (workpiece high)

Figure 7. Hydraulic press for fluid forming and an experimental analyse of process [5]

Slika 7. Hidraulička preša za oblikovanje fluidom i eksperimentalnu analizu procesa [5]

**THE FUNDAMENTALS OF EXPERIMENTAL ANALYSE**

An experimental analyse of forming product of sheet metal helping unpressed fluid enables experimental determining of: fluid pressure, drawing force, force pressure of blankholder of sheet metal, blankholder force pressure unless drawing is with blankholder and product height during drawing process. (Figure 7.) [5].

Mechanical size measuring is made by electrical way. The experimental results have multiple using because they serve for:

- process simulating at the real conditions of forming process,
- determining of technological values that are ground for stochastic process modelling and its optimisation,
- determining of forming forces and dynamics state of process that is ground for tool construction and hydraulic presses choosing,
- plastic process leading at the stability area.

Analysing sheet metal forming process helping fluid is made by measuring of:

- fluid pressure of drawing force (sensor 11),  $F_d$ ,
- fluid pressure at the cylinders of blankholder sheet metal force (sensor 12),  $F_{dp}$ ,
- fluid pressure of blankholder force (sensor 10),  $F_p$ ,
- product height at the drawing process (sensor 13),  $h$  (mm).

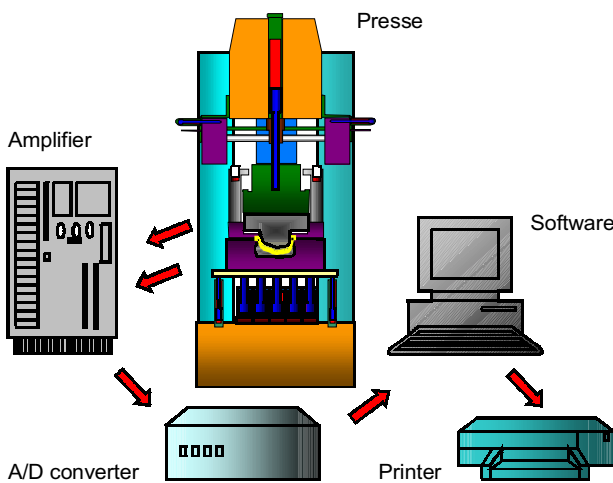

Figure 8. Experimental setup  
Slika 8. Prikaz mjernog sustava

**THE FLUID FORMING PRODUCT EXAMPLES**

**Cylindrical element forming**

At the Figure 9. is given an example of hydromechanical forming of cylindrical element [1].

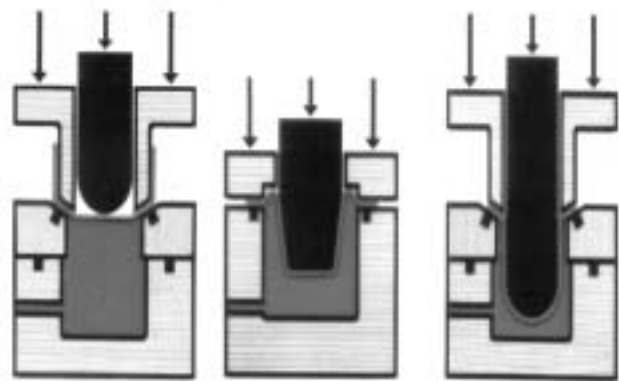

Figure 9. Cylindrical element forming  
Slika 9. Oblikovanje cilindričnih elemenata

**Tube forming**

At the Figure 10. are given the examples of tube forming of different operations and classes.

Dividing operation	Joining operation	Forming operation at the scheme			
					I
					II
					III
					IV
					V

Figure 10. Fluid forming tube  
Slika 10. Oblikovanje cijevi fluidom

It has been getting through classical lengthening simple forms (B, I-V):

- I - class (classical lengthening) hard tool;
- II - class, die is hard, lengthening helping fluid.

**T-shape forming**

Forming of parts of complex forms requires complex (multipart) tool that enables undamaged remove apart from tooling. T-shape forming is made through several phases as shown at the Figure 11. [6].

To decrease the errors into minimum, there is needed knowing of process parameters, their regulation abilities during the forming process, machine choose, helping devices and equipment, cooling means.

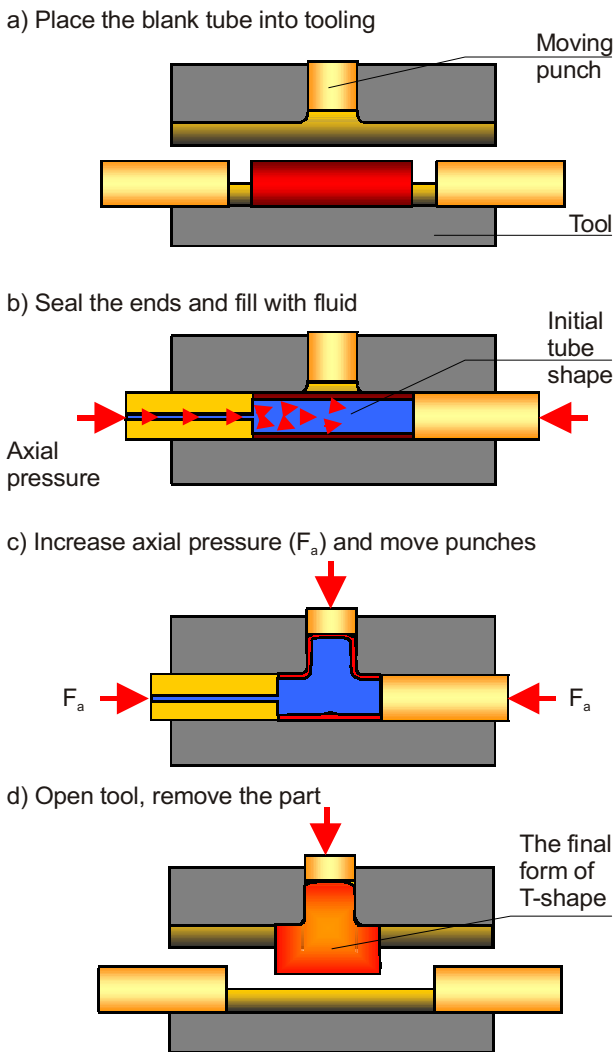

Figure 11. T-shape forming  
Slika 11. Oblikovanje T-račve

### Bicycle frame forming

Forming process at the bicycle frame is similarly to forming at the T-shape producing. The difference is in existing of two ends that are very near and for their making is needed supplied drainage tighten by moving segments. Forming process is in this case symmetrical in according to the plate of sided piece symmetry. The first forming zone is the same as T-shape and at the zone IV don't have influence of axial pressing  $F_1$ , but there becomes stress - state double axes stretching that leads to dividing of ends in these zones. To prevent that at the second phase of forming is made pressing of drainage by moving segments where is reached changing of stress state and drainage of higher.

In this case forming process is symmetrical in according to plate of sided symmetric part. Bicycle frame forming is shown at the Figure 12.

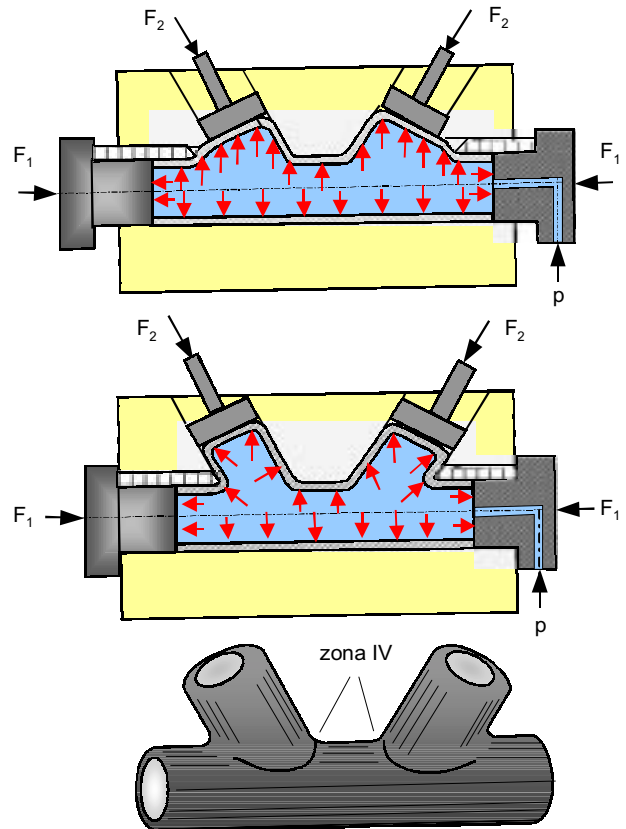

Figure 12. Bicycle frame forming  
Slika 12. Oblikovanje nosećeg rama - spojnice bicikla

### The other produced by fluid forming

The fluid forming has specific importance at the forming parts at the car industry, shipbuilding, military industry. Some examples are shown at the Figure 13.



Figure 13. The different products produced by fluid forming  
Slika 13. Različiti proizvodi dobiveni oblikovanjem pomoću fluida

## CONCLUSIONS

The application of fluid at the forming of metal products has multiple advantages and here are the most important:

1. It hasn't tube wall thickness that is disadvantages at the hard tool forming.
2. The high quality of processed surfaces because smaller friction forces and tangential stress.
3. It hasn't holes at the material because decreasing of contact stress.
4. The simple tool, because it is made by half hard tool, since the another tool is fluid.
5. The automatisisation possibility and optimization of processing lead the fluid processing in the top of forming processes.
6. The technological demands referred to material kind and characteristics that are formed as well as to fluid sort and class of fluid forming and optimisation of processing parameters.
7. The possibility of complex element producing of big dimensions (car industry, shipbuilding, military industry).
8. High level of dimension and geometry product accurateness.
9. The fluid pressure must be at the correctly limits because it determines the power of hydraulic device.  
The force values must be known at all phases of forming to make press choosing and design of tool in according to applying of more quality lubricating means.  
The increasing of fluid forming at the technological developed countries is 5 to 10% per year in according to classical forming processes.

## REFERENCES

- [1] M. Jurković, H. Đukić, Z. Burzić, *Moderne proizvodne tehnike i tehnologije*, Poslijediplomski studij, Tehnički fakultet, Bihać, 2003.
- [2] V. Stoiljković, *Reverzibilno izvlačenje cilindričnih elemenata nestišljivim fluidom*, Zbornik radova: Obrada deformisanjem u mašinstvu, Novi Sad, 1984, str. 173 - 185.
- [3] B. Rančić, *Sila zatvaranja alata pri oblikovanju nestišljivim fluidom delova sa bočnim odvodima*, 22 jugoslovensko savjetovanje za proizvodno mašinstvo, Ohrid, 1989.
- [4] B. Rančić, *Određivanje radnog pritiska i sila pri oblikovanju T-račve sa sužavanjem odvoda*, 22 jugoslovensko savjetovanje za proizvodno mašinstvo, Ohrid, 1989.
- [5] Source Thyssen Krupp H//[www.hydroforming.net/](http://www.hydroforming.net/)
- [6] <http://nsmwww.eng.ohio-state.edu/>
- [7] M. Dvořák: A Contribution to the Investigation of the structure of Drawn Shells Produced by the Metod of Hydromechanical Drawing, *Journal for Technology of Plasticity*, 26 (2001) 1, 33 - 37.