

TRIBOLOGICAL PROPERTIES OF BRAKE SHOES WITH INCREASED PHOSPHORUS CONTENT

Received - Primljeno: 2004-01-16

Accepted - Prihvaćeno: 2004-06-20

Preliminary Note - Prethodno priopćenje

The research has been conducted applying dry friction method using logs made out of brake shoes, sliding them on rotating disc out of the same material as the train wheels. Chemical composition, structure and hardness of the brake shoes and their influence on brake shoe wear were tested under simulated laboratory conditions: wheel - brake shoe. It has been found out that brake shoe wear resistance depends mainly upon phosphorus content and the structure, much more than on hardness values.

Key words: *train wheels, shoes, phosphorus content, wear*

Tribološka svojstva kočnih papuča s povišenim udjelom fosfora. Ispitivanje je provedeno u uvjetima suhog trenja sklizanja kladica izrađenih iz kočnih papuča po rotirajućem disku od istog materijala iz kojega se izrađuju i kotači vlakova. Analiziran je utjecaj kemijskog sastava, strukture i tvrdoće papuča na trošenje u simuliranim uvjetima ispitivanja kotač - papuča na tribološkom uređaju u laboratoriju. Utvrđeno je da otpornost trošenju papuča mnogo više ovisi o udjelu fosfora i strukturi nego o tvrdoći.

Ključne riječi: *kotači vlakova, papuče, udjel fosfora, trošenje*

INTRODUCTION

Wear resistance and the related train brake shoe material wear have always been real safety issue, which always attracted additional attention, especially in time of introduction of high speed trains, because an old adage says "a train does not have to start, but it must stop". On journey there are changes going on in tribology system - rails- wheel - brake shoe. Materials are worn out, especially those having lower price, and requiring simple substitutions, changes in structure due to high contact pressures and temperature increase occur, and lead to alternation of mechanical properties and hardness of the surface layers.

Production of brake shoes and their properties are based on requirements defined with standard UIC 832-V [1] and domestic regulations [2], which determine chemical composition and structure of phosphorus gray casting used for manufacture of train brake shoes, their hardness values, as well as impact testing and properties of the "armature". According to these regulations phosphorus content may range from the lower value of 0,8 % to the upper allowed limit of 1,1 %, while Brinell hardness value varies (ball diameter 10 mm and the force 29,400 N) from minimal 197 to max. 255 HB.

Regarding melting inlet composition and founding technology, the long time process quality control introduced in production process ensured that train brake shoes were largely produced within the range of the recognized chemical composition and hardness value parameters. Sometimes measured hardness values approached those of boundary values, but seldom exceeded set tolerances. The same applied to phosphorus content values.

In the perspective of previously specified phenomena, such as occurrence of high temperature during train braking, observed dissipation of the phosphorus content and the measured hardness values, and the need to maintain high journey safety level, wear resistance testing were carried out on laboratory samples, in condition of simulated operation of wheel and the brake shoe.

The goal of this research was to find out the amount of brake shoe wear dependent on its chemical composition, hardness and structural constituent parts, and number of wheel revolutions ("speed").

EXPERIMENTAL WORK

Experimental plan and test conditions

Laboratory wear testing was conducted on samples produced from three charges of brake shoes, having different chemical composition and hardness values (Table 1.) com-

V. Marušić, I. Vitez, I. Kladarić, Faculty of Mechanical Engineering University of Osijek, Slavonski Brod, Croatia

ing into contact with the counter body in the form of disc. Each charge yielded 6 brake shoe samples needed for carrying out of laboratory wear tests, three for smaller (1,000 min⁻¹) and three for greater (1,300 min⁻¹) number of disc revolutions.

As previous hardness controls of wheel surfaces determined differences between new and the worn wheels, laboratory testing anticipated heat treatment of test samples to the hardness value of 300 HB, the value which was measured on the newly manufactured wheels. Total number of six disc samples were produced, one set for bigger and the other set for smaller number of revolutions for each brake shoe charge. Discs were machined on the lathe so as to have the same surface roughness as the newly manufactured wheels ($R_{a,max} = 12 \mu\text{m}$), and were made out of steel, which by its chemical composition corresponded to designation R 9 [3], and is used for production of mono-bloc wheels on electric locomotives out of the series 441 and 442 - the most representative locomotive on domestic rails.

Table 1. shows that brake shoes out of charge 1 are on the bottom boundary of the approved phosphorus content, white charge 2 takes the middle position. Brake shoes out of charge 3 display phosphorus content on the upper allowed limit, with carbon content and average hardness value HB slightly above the approved values.

Table 1. Chemical composition and hardness of train brake shoes
 Tablica 1. Kemijski sastav i tvrdoća kočnih papučica

Brake shoes (charge)	Chemical composition / %					Hardness * HB
	C _{uk}	Si	Mn	S	P	
1	3,14	1,89	0,99	0,121	0,92	203
2	3,28	1,67	0,84	0,124	1,01	242
3	3,35	1,74	0,91	1,130	1,10	258

*Average value out of 30 measures (10 measurements on three brake shoe cross sections)

Wear resistance testing was conducted on the laboratory device SCMT1-2070 [4]. The sample size is shown in the sketch, and their position on device can be seen on the photo in Figure 1.

Experiment plan projected to maintain constant pressure between brake shoe and the disc during testing, which was controlled by dynamometer DOSM 3-0,2, delivered together with tribo- device. Taking into consideration recommendation [5] to limit specific pressure on the shoe during braking of the train to $p_{max} < 1,2 \text{ MPa}$, so as to reduce negative influence of the heat, we selected or laboratory testing purposes pressure with force of 220 N. As the brake shoe friction surface amounts to 200 mm², calculated specific pressure between brake shoe sample and the disc equalled 1,1 MPa. Temperature measurement of the brake shoe sample by application of thermocouple NiCr-Ni connected on digital thermometer DT 02 was also foreseen.

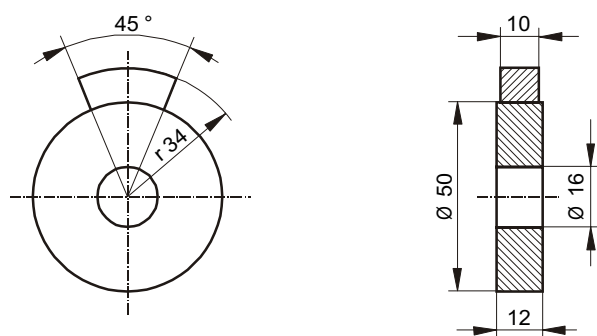

girder sample of shoe

sample of brake shoe

sparkle

sample of disc

Figure 1. Samples and wear resistance testing device SMT 1-2070
 a) size of disc sample and brake shoe
 b) position of sample on device during testing of appearance of sparkling

Slika 1. Uzorci i uređaj za ispitivanje trošenja SMT 1-2070
 a) dimenzije uzoraka diska i papučice
 b) položaj uzoraka na uređaju prilikom pokusa i pojava iskrenja

Brake shoe structure properties

Brake shoe composition structure from the surface to the core was established as predominantly perlitic structure, with presence of less than 5% of ferrite (somewhat more expressed towards the surface). It is characteristics that brake shoes out of charge 2 and 3, when compared with charge No. 1 brake shoes, display presence of phosphide eutectic nests towards the middle part of structure. Typical brake shoe sample structures with visible indentation from hardness measurements HV 0,1 are shown in Figure 2. The measured perlitic hardness values for all three charges are approximately equal and ranged from 300 to 350 HV 0,1 m with phosphide eutectic values from 776 to 836 HV 0,1. Hardness measurements according to Brinell ($HB_{10/3000/30}$), on three cross sections of the brake shoes with 10 measurements showed that the measured values for brakes out of charge No. 1 ranged between 195 until 216 HB, and with brakes from charge 2 between 217 to 253 HB. This is probably consequence of the increased presence of phosphide eutectic nests, because with brake

shoes out of charge No. 3, hardness values ranged between 233 and 271 HB.

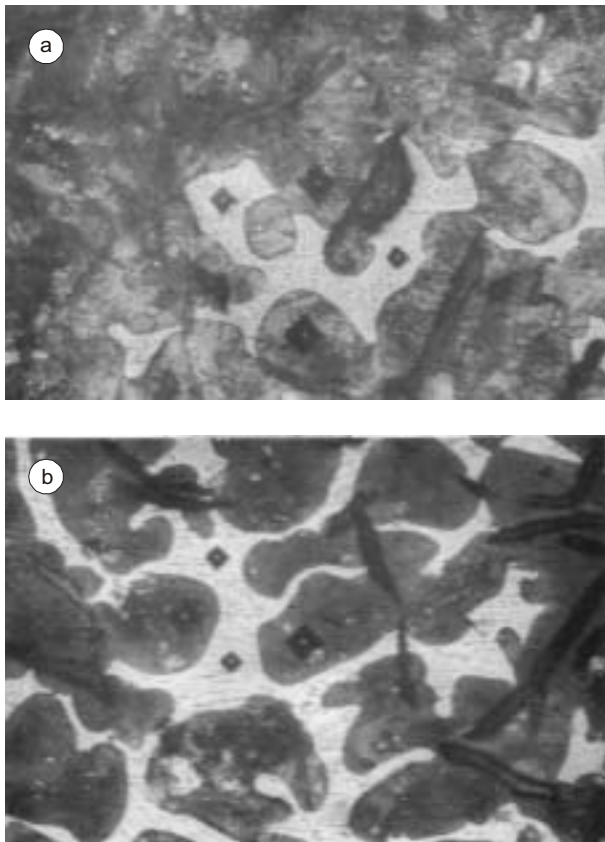

Figure 2. Characteristic microstructure of brake shoes and prints of micro hardness measurements HV 0,1. Nital etched. Magnification 200 ×.
 a) brake shoes with 0,8 % P, b) brake shoes with 1,10 % P
 Slika 2. Karakteristična mikrostruktura kočnih papuča i otisci mjerenja mikrotvrdoće HV 0,1. Nagriženo nitalom. Povećanje 200 ×.
 a) papuča s 0,82% P, b) papuča s 1,10 % P

Wear resistance test results

Weighing scales METTLER H 311 (precision 10^{-4} g) was used for monitoring of wear resistance of samples by weighing of amount of the mass loss.

Only from time to time dimensional control of the worn brake shoe samples was carried out (measuring precision 10^{-1} mm), primarily to prevent that dimensional wear may reach “critical” values, after which bolts, fixing position of the brake shoe sample with support, come into contact with rotating disc.

Testing of brake shoe samples was conducted with two different number of disc revolutions in the time unit: lower at $1,000 \text{ min}^{-1}$ and the higher at $1,300 \text{ min}^{-1}$. Mass weight loss of the brake shoe sample at $1,000 \text{ min}^{-1}$ was conducted at every 7,500 disc revolutions (cycle) and at $1,300 \text{ min}^{-1}$ after every 10,500 disc revolutions (cycle). Brake shoe wear

resistance results with 0,82 % P are shown in diagrams in Figure 3., brake shoes with 1,01 % P in Figure 4. and brake shoe with 1,10 % P content in diagram in Figure 5.

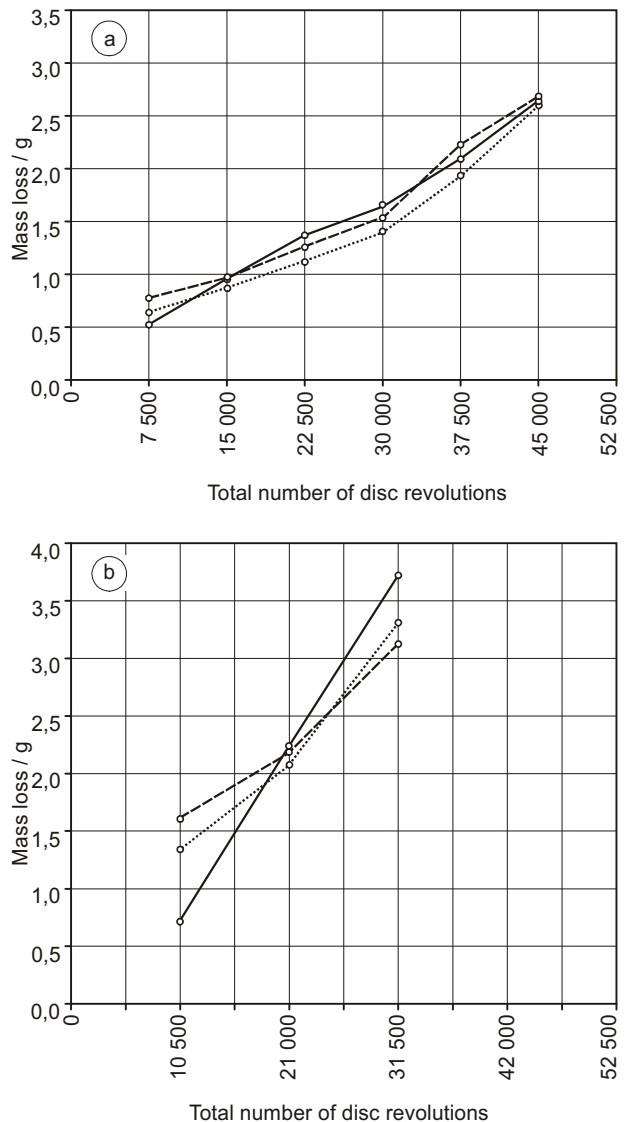

Figure 3. Review of brake shoe sample mass loss with 0,2 % P content

a) number of revolutions of the disc = $1,000 \text{ min}^{-1}$
 b) number of revolutions of the disc = $1,300 \text{ min}^{-1}$

Slika 3. Dijagramski prikaz gubitka mase uzoraka papuča s udjelom 0,82% P

a) broj obrtaja diska = $1,000 \text{ min}^{-1}$
 b) broj obrtaja diska = $1,300 \text{ min}^{-1}$

Mass loss of discs also measured. Comparative evaluation of mass loss measurements on each disc, after completion of testing on all three brake shoe samples, showed very small differences, observable only at the third decimal. Such small amount of wear can to be attributed to total number of disc revolutions prior to reaching of critical wear resistance of the brake samples.

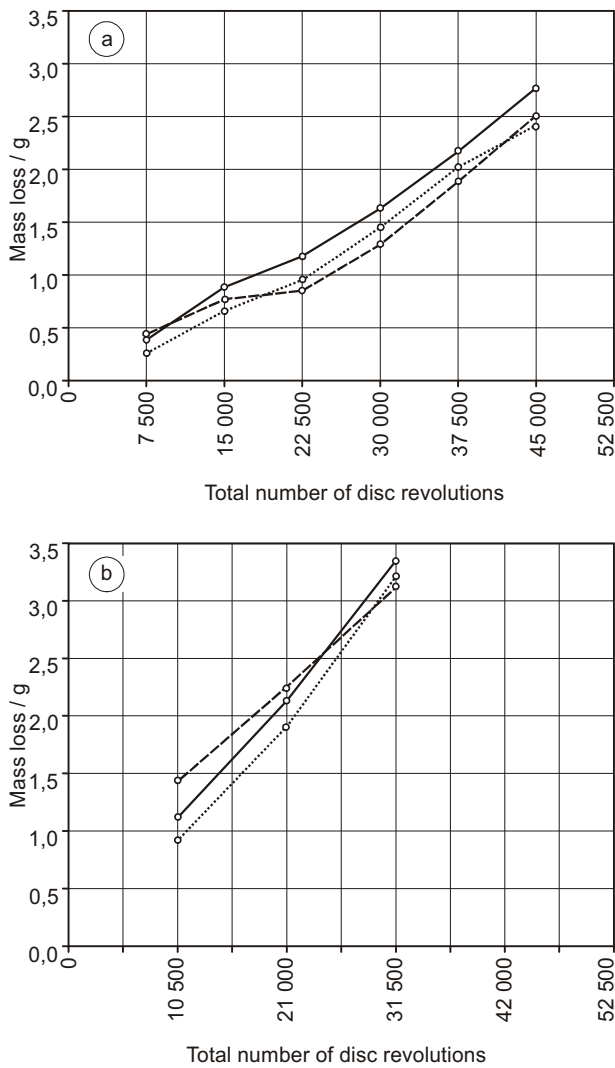

Figure 4. Review of brake shoe sample mass loss with 1,01 % P content

- a) number of revolutions of the disc = 1,000 min⁻¹
- b) number of revolutions of the disc = 1,300 min⁻¹

Slika 4. Dijagramski prikaz gubitka mase uzoraka papuča s udjelom 1,01 % P

- a) broj obrtaja diska = 1,000 min⁻¹
- b) broj obrtaja diska = 1,300 min⁻¹

MASS LOSS ANALYSIS AND THE LINKS WITH BRAKE SHOE STRUCTURE AND HARDNESS VALUES

Similar to braking shoes, which get heated during train braking operation, laboratory samples were also heated during experiment. Temperature measured by thermocouple NiCr-Ni in the contact zone brake shoe - disc reached values of 9000 °C. The observed phenomenon of sparking, which is typical for gray castings [6] is shown in Figure 1b.

Comparative analyses of brake shoe wear (diagrams given in Figure 3., 4. and 5.) show initially (up to 15,000

disc revolutions) smaller mass loss on brake shoes with larger phosphorus content and greater hardness value. Later on, with increase of total number of revolutions (cycle), this difference is reduced and vanishes. Subsequent brake shoe composition structure control and hardness HB and micro hardness measurement HV 0,1 of phosphid eutectic

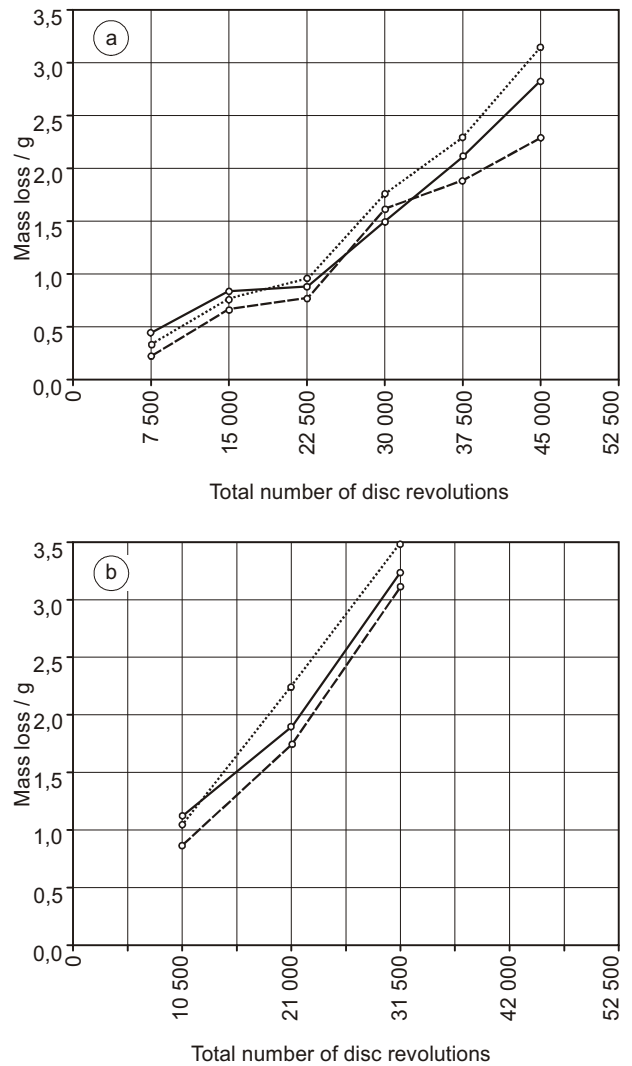

Figure 5. Review of brake shoe sample mass loss with 1,10 % P content

- a) number of revolutions of the disc = 1,000 min⁻¹
- b) number of revolutions of the disc = 1,300 min⁻¹

Slika 5. Dijagramski prikaz gubitka mase uzoraka papuča s udjelom 1,10% P

- a) broj obrtaja diska = 1,000 min⁻¹
- b) broj obrtaja diska = 1,300 min⁻¹

showed drop in values in relation to hardness values measured prior to experiment. Annealing tests of the samples were conducted in furnace as different temperature values ($\vartheta_{z1} = 700$ °C, $\vartheta_{z2} = 800$ °C, $\vartheta_{z3} = 900$ °C), which also proved decrease of hardness values. Brake shoe sample structure analysis after wear and samples after annealing

did not show that annealing had any visible influence on the form and distribution of graphite flakes, as well as on distribution of perlite, i.e. phosphide eutectic. Characteristic structures of brake shoe samples after annealing are presented in Figure 6. Simultaneously with measurement

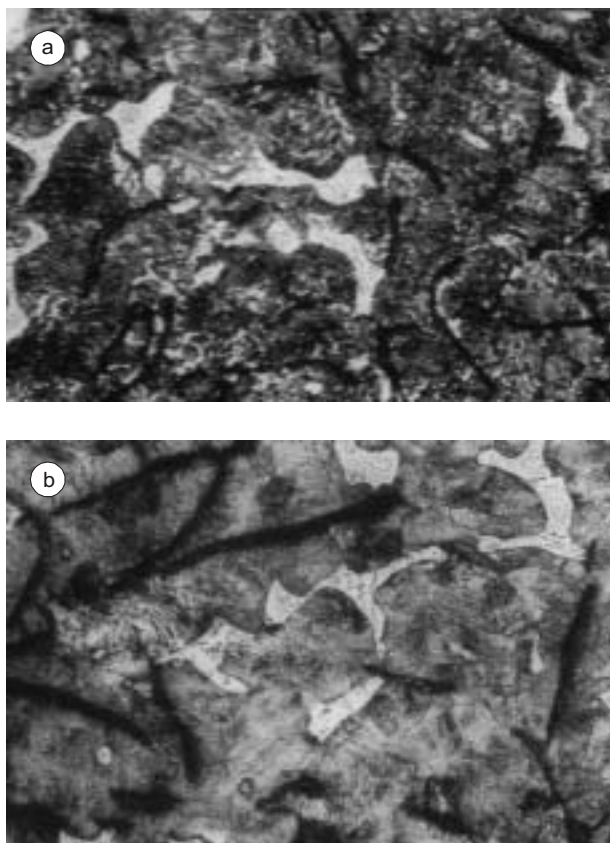

Figure 6. Characteristic structure of brake shoes after heating at $\vartheta \approx 900\text{ }^{\circ}\text{C}$, air cooling. Nital etched. Magnification $200\times$.

a) samples annealed in the furnace at $900\text{ }^{\circ}\text{C}$

b) samples after wear resistance testing

Slika 6. Karakteristična struktura papuča nakon ugrijavanja na $\vartheta \approx 900\text{ }^{\circ}\text{C}$, hlađenje na zraku. Nagriženo nitalom. Povećanje $200\times$.

a) uzorci žareni u peći na $900\text{ }^{\circ}\text{C}$

b) uzorci nakon ispitivanja trošenja

of micro hardness no “softening” of perlite could have been detected, but therefore hardness of phosphid eutectic showed decreased values from 700 to 744 HV 0,1. The same applies to brake shoe samples tested at higher and lower number of disc revolutions.

CONCLUSION

After evaluation of phosphorus content and its influence on hardness values, it may be concluded that brake

shoes with the higher phosphorus content, 1,01 % P, on average 20% and those with 1,10 % P even with 30 % are harder than those having 0,82 % P values. This difference in hardness can be attributed to greater extraction of phosphid eutectic, mainly in the form of nests.

Laboratory test results show that favourable influence of greater phosphorus content is stronger to be noticed at the beginning of braking test. It is manifested through less significant loss of the brake shoe mass with shoes having larger phosphorus content. With the increase of braking cycle, this difference decreases significantly, and almost disappears - as the consequence of brake shoe heating during braking operation. High temperatures and the ensuing slow cooling off leads to decrease of general hardness values of the shoes (HB), mainly as consequence of reduction of micro hardness of phosphid eutectic from $\gg 800\text{ HV }0,1$ on 700 to 750 HV 0,1.

The influence of greater number of disc revolutions in the time unit (“speed”) is expressed in more intensive wear of the brake shoes at greater rpm. It is extraordinarily important that brake shoes start to heat up under such conditions, and that the annealing does not reduce their hardness value. Tests carried out with brake shoe samples under laboratory conditions showed that annealing does not lead to any equalization of hardness values between shoes having higher and lower phosphorus content. Furthermore structure analyses showed no discernible changes of form and distribution of graphite flakes, perlite and phosphid eutectic. As from general tribological standpoint [7] it would be desirable that structures supporting wear resistance properties (“harder constituent parts”) would be distributed more equally in the surrounding matrix (“softer matrix”), conclusion is that from the standpoint of train braking on the rails, priority should be given to braking shoes having perlitic matrix with tinier extracted graphite flakes and more equally distributed phosphid eutectic.

REFERENCES

- [1] UIC - Kodeks 832 V: Technische Lieferbedingungen ilir Bremssklotsoklen aus Phosphorgu-eisen ilir Triebfahrzeuge und Wagen, 2. Ausgabe, 1993.
- [2] HŽ Služba za vuču i željeznička vozila: Tehnički uvjeti za izradu i isporuku kočnih papuča od sivog lijeva s povišenim sadržajem fosfora, oznake P10, Zagreb, 1994.
- [3] M. Brkić, N. Ujaković: Električna vučna vozila, Željeznička tehnička škola u Zagrebu, Zagreb, 1992., str. 30.
- [4] Uredaj za ispitivanje materijala na trenje i trošenje SMT 1-2070, Tehnički opisi i upute za eksploataciju 2.779.013-01 TO.
- [5] S. Vranić: Kočenje vlakova, Tvornica željezničkih vozila Gredelj, Zagreb, 2000., str. 94.
- [6] V. M. Vujatović, M. Stojanović: Ispitivanje čelika metodom varničenja, Jugoenergetik, Beograd, 1979., str. 85 - 125.
- [7] V. Ivušić: Tribologija, HDMT, Zagreb, 1998., str. 18 - 24.