

INFLUENCE OF THE CYCLING LOADING METHOD ON THE FATIGUE LIFE OF SURFACE-HARDENED STEEL SHEETS

Received - Primljeno: 2003-12-04

Accepted - Prihvaćeno: 2004-05-20

Preliminary Note - Prethodno priopćenje

The paper analyses the influence of blasting under the following conditions: the size of blasting particles of 0,9 mm, the impact angle of 75° and the pressure of 0,5 MPa on the fatigue properties of blasted sheets made of RSt 37-2 grade. Blasting, as one of the ways of the surface hardening and the surface preparation before surface finish, results in the hardening and the increase in roughness of sheet. The above-mentioned facts influence the fatigue process in the dependence on the cycling loading method. During tension fatigue tests with the tension-zero cycle, the fatigue limit of as-blasted sheet decreased and during symmetrical bending fatigue tests its fatigue limit increased. The paper analyses the causes of the measured results.

Key words: *cycling loading method, fatigue, blasting, hardening*

Utjecaj metode cikličnog opterećivanja na umor otvrdnute površine čeličnih limova. U radu se analizira utjecaj pjeskarenja zrcima od 0,9 mm, kutom udara od 75° i tlakom od 0,5 MPa na umor pjeskarenih limova kvalitete RSt 37.2. Pjeskarenje kao jedan od načina otvrdnjavanja i pripremanja površine prije konačne obrade dovodi do otvrdnjavanja i povećanja hrapavosti lima. Gore spomenute činjenice utječu na proces umora ovisno o metodi cikličnog opterećivanja. Tijekom ispitivanja umora na vlak s ciklusom vlaka jednakim nuli, granica umora pjeskarenog lima se smanjuje a tijekom ispitivanja umora na simetrično savijanje povećava. Članak analizira uzroke izmjerenih rezultata.

Ključne riječi: *metode cikličkog opterećivanja, umor, pjeskarenje, otvrdnjavanje*

INTRODUCTION

The fatigue process consists in the nucleation and propagation of cracks and it is a function of internal and external factors. The nuclei of the fatigue fracture are formed, as a rule, on the surface of a part during tension stress. An increase in the surface strength also results in an increase in the fatigue limit. It is ideal to introduce compressive stress into the surface layers. Blasting is one of technologies that make it possible to increase the surface strength due to plastic deformation and at the same time to introduce compressive stress into the surface. Blasting is used as a preparation step for the subsequent coating, so that the coating can have required properties [1], but also as one of technologies of surface hardening of finished products with suitable physical and mechanical properties

[2]. In either case, blasting should not result in a decrease in the mechanical properties of blasted parts.

In the light of the fatigue process, the blasted surface needs to be assessed from two points of view. Blasting causes intensive plastic deformation of a thin surface layer, which results in the formation of residual compressive stress in this layer [3 - 5]. This has a positive effect on the fatigue process. On the other hand, blasting increases the surface roughness and possibly results in the formation of micro-cracks, which has a negative effect on the fatigue process and decreases the fatigue resistance [6, 7]. The condition of the surface of blasted material depends on the blasting conditions [7]. Therefore it is important to optimise them.

The fatigue process and the fatigue life depend on external factors, which include the method of cycling loading [8, 9]. During tension cyclic loading, the whole cross section is loaded with the same cyclically changing stress, but in case of bending cyclic loading the maximum stress takes place on the surface and it decreases inwards. Therefore in surface hardened materials the fatigue life can significantly be influenced by the loading method [10].

K. Kovalová, Faculty of Mechanical Engineering Technical University of Košice, Košice, Slovakia, I. Mamuzić, Faculty of Metallurgy University of Zagreb, Sisak, Croatia, M. Buršák, Faculty of Metallurgy Technical University of Košice, Košice, Slovakia

The paper is aimed at analysing the influence of the loading method (tension, bending) on the fatigue properties of surface-hardened steel sheet.

MATERIAL AND EXPERIMENTAL METHOD

For experiments, hot rolled steel sheet of RSt 37-2 grade with the thickness of 3 mm was used. The structure of steel sheet is almost entirely ferritic with the grain size $d_{st} = 0,012$ mm.

Samples were taken from the tested sheet in the rolling direction and test bars were made for tension and fatigue tests (see Figure 1.). The test bars were ground on both

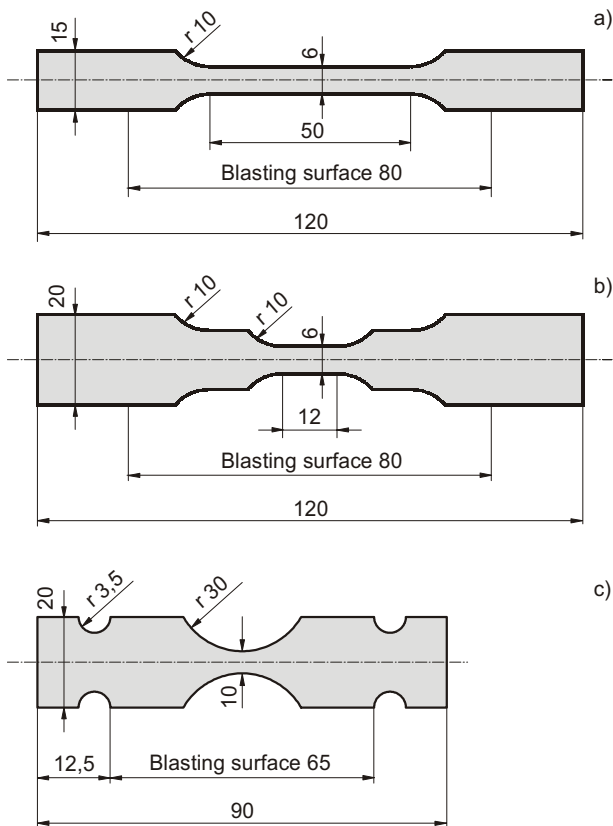

Figure 1. Tensile test bars (a) and tensile (b) and bending (c) fatigue test bars

Slika 1. Epruvete za ispitivanje na vlak (a), na umor zbog vlačnog naprezanja (b), na umor zbog savijanja (c)

sides and some of them were blasted on all sides using a pneumatic blasting device from Wonisch Company. The blasting was carried out under the following conditions: pressure $p = 0.5$ MPa, impact angle of steel granulate with the hardness of ca 500HV $\alpha = 75^\circ$ and granulate diameter $d = 0.9$ mm.

On as-ground and as-blasted specimens, the surface roughness was measured and the mean arithmetical deviation R_a , the max. profile height R_z and the microhardness HV 0.01 were evaluated. Tensile tests were made on a ten-

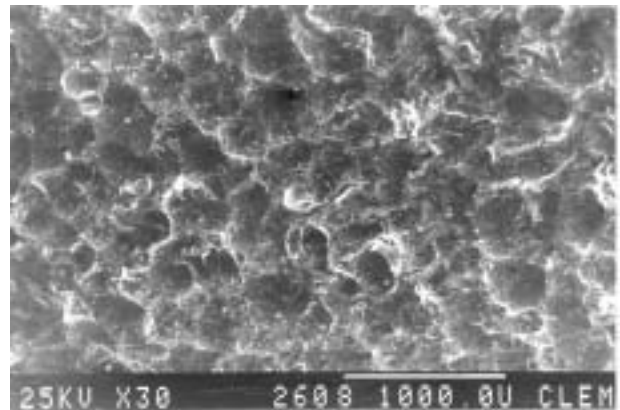

Figure 2. As-blasted sheet surface
Slika 2. Pjeskarena površina lima

sile testing machine INSTRON 1185. Fatigue two-side bending tests with the symmetrical cycle were made on a fatigue testing machine PWOG by Carl Schenke company at the frequency of 35 Hz and fatigue tensile tests with the tension-zero cycle were made on a fatigue testing machine INSTRON 8511 at the frequency of 20 Hz.

ACHIEVED RESULTS AND THEIR ANALYSIS

The surface of as-blasted tested sheet is shown in Figure 2. and the surface profile is shown in Figure 3. The blast-

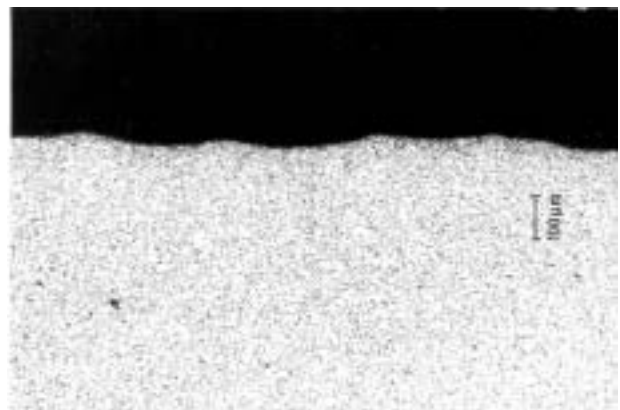

Figure 3. Microstructure of as-blasted surface sheet profile
Slika 3. Mikrostruktura pjeskarene površine limenog profila

ing resulted in a significant increase in the surface roughness. The as-ground sheet had the mean values of $R_a = 0,27 \mu\text{m}$ and $R_z = 1,56 \mu\text{m}$ and the as-blasted sheet at the selected blasting parameters $p = 0.5$ MPa, $\alpha = 75^\circ$ and $d = 0,9$ mm had the mean values of $R_a = 10,27 \mu\text{m}$ and $R_z = 54,55 \mu\text{m}$. The surface of the as-blasted samples is deformation hardened to the depth of ca 0,06 mm, as documented by Figure 4., and the microhardness course as documented by Figure 5. The surface hardness is 35 HV0,01 more than that of the basic material.

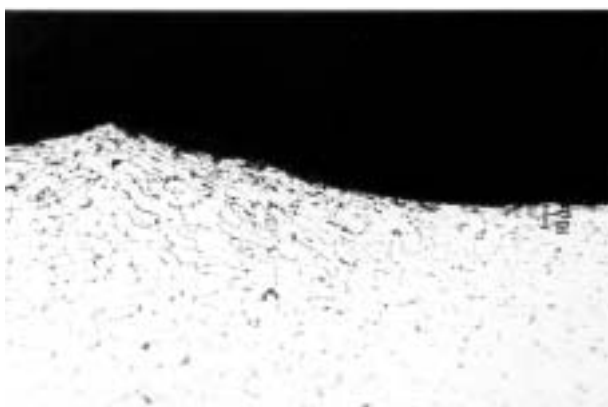

Figure 4. Microstructure of blasted deformation hardened sheet layer
Slika 4. Mikrostruktura sloja lima otvrdnutog deformiranjem pjeskarenjem

It results from this analysis that a change in the properties of the blasted surface influences its mechanical properties, while the degree of the influence depends on the

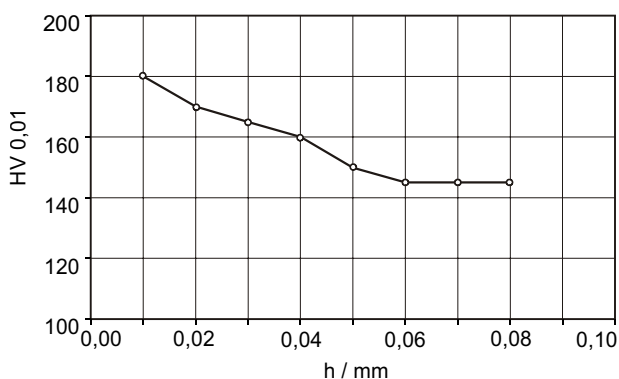

Figure 5. Course of microhardness HV0,01 in blasting hardened sheet layer h
Slika 5. Crta prostiranja mikrotvrdoće HV0,01 u sloju lima h otvrdnutog pjeskarenjem

loading method. The influence of blasting on the basic mechanical properties is shown in Figure 6. The experimental results show that blasting caused an increase in the yield point R_e , a decrease in tensile strength R_m and elongation A_5 . The influence of blasting on the change in basic mechanical properties is more significant when the thickness of blasted sheet is lower. This is due to a change in the ratio of the blasting-hardened volume to the overall volume of the tested sheet sample. Since the hardened volume depends on the blasting conditions and does not depend on the sheet thickness, with an increasing sheet thickness its ratio decreases, and hence its influence on the change in mechanical properties also decreases. The resulting properties of surface deformation hardened sheet are given by the superposition of the tension diagrams of the deformation hardened layer and the basic material.

These resulting properties can be influenced by the surface roughness, but also by “friction” forces between the hardened layer and the non-hardened core.

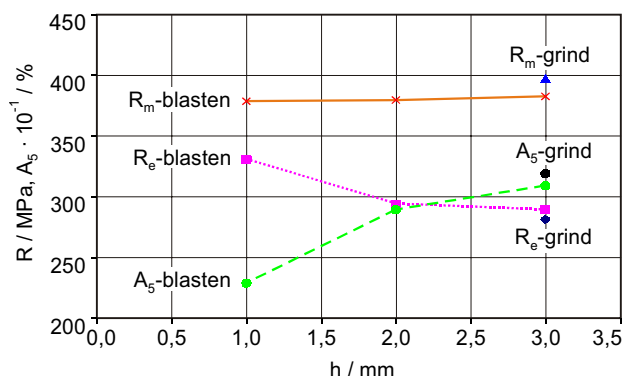

Figure 6. Influence of blasting and sheet thickness h on yield point R_e , tensile strength R_m and elongation A_5
Slika 6. Utjecaj pjeskarenja i debljine lima h na granicu razvlačenja R_e , vlačnu čvrstoću R_m i izduženje A_5

During cyclic loading, the fatigue process usually begins on the surface and therefore the properties of the surface layer play a crucial role. Figure 7. shows Wöhler curve

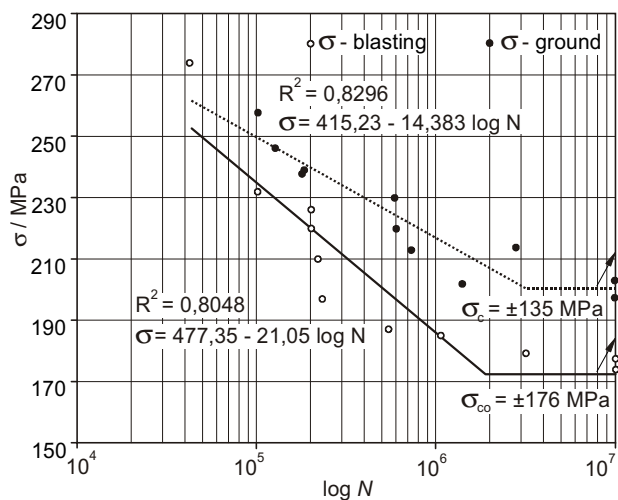

Figure 7. Wöhler curves of as-ground and as-blasted samples, two-side symmetrical bending
Slika 7. Wöhlerove krivulje brušenih i pjeskarenih uzoraka, dvostrano simetrično savijanje

obtained experimentally on as-ground and as-blasted samples, which were tested under the two-side bending and the symmetrical cycle. It results from the measured results and their statistical processing that blasting increased the fatigue limit σ_{co} by 12 %. It results from comparing the parameters a, b of the equation $\sigma = a - b \cdot \log N$, of the inclined part of Wöhler curve that the time fatigue limit of as-blasted samples is higher and its band is also broadened. The results confirm that blasting has a positive effect on fatigue properties under cyclic two-side bending loading.

Figure 8. shows the relationship between the upper stress and the number of cycles measured during fatigue tests with the tension-zero cycle. The results show that the fatigue limit σ_c of the as-blasted samples is ca 10 % lower than that of the as-ground ones and their time fatigue limit is also lower (a shift of the inclined part of Wöhler curve to left).

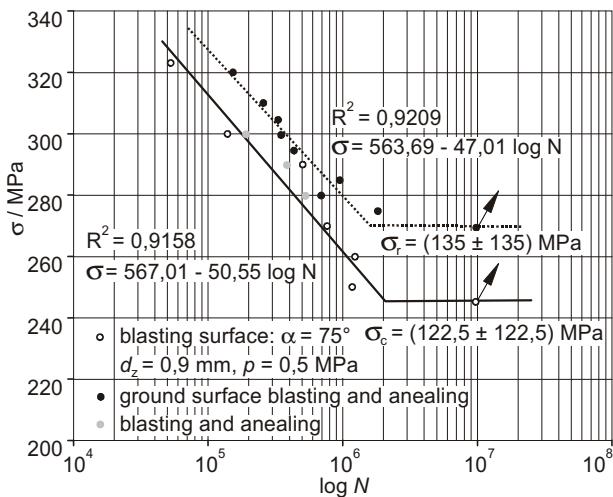

Figure 8. Wöhler curves of as-ground and as-blasted samples, tension-zero cycle
 Slika 8. Wöhlerove krivulje brušenih i pjeskarenih uzoraka, nulto naprezanje na vlak

As the experiments show, the fatigue properties of the blasting surface hardened samples made of steel grade RSt 37-2 is significantly influenced by the loading method. A thin blasting deformation hardened layer causes the formation of compressive stress on the sheet surface, while the surface has also higher strength properties, which has a positive effect on the fatigue properties. On the other hand, blasting significantly increases the surface roughness, but also results in the formation of tensile stress under the deformation-hardened layer (see Figure 9.), which has a negative effect on fatigue properties. The fatigue loading method remains crucial and will prevail among the above-mentioned factors in the fatigue loading of sheet with a thin (0,06 mm) surface hardened layer. In case of tensile loading with the tension-zero cycle the stress can be considered as constant within the whole cross section. Under the hardened surface, tensile stress is formed (see Figure 9.), which is added to-

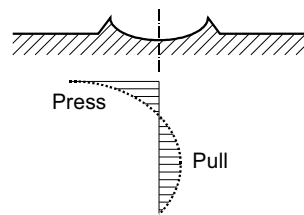

Figure 9. Model of residual stress under blasted surface
 Slika 9. Model zaostalog naprezanja pod pjeskarenom površinom

gether with the tensile stress from loading, and there may arise conditions for the formation of the nucleus of a fatigue failure under the hardened surface. An increase in the roughness of the blasted surface (a notch effect) accelerates the growth of this nucleus towards the surface, and hence its propagation within the whole cross section, which results in a decrease in the fatigue limit of the tested blasted sheet. During cyclic symmetrical bending loading, the stress from this loading changes in the cross section of the sheet. A max. stress is on the surface and it decreases inwards to zero, i.e. the fatigue process begins on the surface, and hence the surface hardening and the compressive stress induced by it prevail over the negative effects of the increased roughness of the blasted sheet surface, therefore its fatigue resistance, bending fatigue limit and time fatigue limit increase.

CONCLUSION

The aim of the paper was to assess the influence of surface blasting of steel sheet with the thickness of 3 mm made of RSt 37-2 grade. It resulted from the experimental results and their analysis that:

- blasting increased the yield point and decreased the elongation. These changes are a function of the sheet thickness; the thinner sheet, the more significant these changes,
- blasting increases the surface roughness of the tested sheet by an order, deformation hardening of the surface takes place to the depth of ca 0,06 mm,
- the cyclic loading method significantly influences the fatigue characteristics of the blasted sheet,
- tension loading with the tension-zero cycle decreased and two-side symmetric loading increased the fatigue limit, as well as the time fatigue limit of the blasted sheet.

REFERENCES

- [1] V. Bačová: Secondary effects of blasting in sheet surface pretreatment, In.: "Eurometal working 96", Bratislava, (1996), 178.
- [2] D. Kniewald: Blasting surface preparation under coatings, Korozna ochrana materialu, 32 (1998), 42.
- [3] V. Sedláček: Surface and coatings of metals, Praha, (1992).
- [4] M. Klesník: Cyclic deformation and fatigue of metals, VEDA Bratislava, (1987).
- [5] R. A. Chermenhoff, I. Mocarski: Increased Fatigue, (1996) 5, 104.
- [6] M. Buršák, I. Mamuzič, M. Mihaliková, Metalurgija 43 (2004) 2, 101 - 105.
- [7] K. Kovalová, J. Michel', Acta Mechanica Slovaca 7 (2003), 4 - A, 127.
- [8] M. Mihaliková, E. Čizmarová, M. Buršák: Influence of deformation and temperature on properties of cold forming microalloyed steels: In.: "Transfer 2003", Trenčín 23 - 24.10.2003, 306.
- [9] F. Trebuňa, M. Buršák: Terminal state - breaks, Grafotlač, Prešov, (2002).
- [10] S. Věchet, S. Kohout, O. Bokůvka: Fatigue properties of nodular cast iron, ŽU, Žilina, (2002).