

A NEW METHOD OF MANUFACTURING SMALL-DIAMETER BARS AND TUBES FROM HARDLY DEFORMABLE STEELS IN SKEW ROLLING

Received - Primljeno: 2006-06-21

Accepted - Prihvaćeno: 2006-11-22

Preliminary Note - Prethodno priopćenje

The paper discusses the process of hot rolling on skew rolling mills and compares it with other methods of manufacturing rods (shape milling) and tubes (pilger rolling). The method and results of calculation of the optimal price of a three-roll skew rolling mill taking into account the benefits for the purchaser and the manufacturer are given.

Key words: *hot rolling, skew rolling, rods, tubes, hardly deformable materials*

Nova metoda proizvodnje šipki malog promjera i cijevi od teško oblikovljivog čelika kod kosog valjanja. U članku se razmatra proces vrućeg valjanja kod valjaonica s kosim valjanjem i uspoređuje se s drugim metodama proizvodnje šipki (valjanje oblika) i cijevi (pilger valjanje). Predstavljene su metoda i rezultati proračuna optimalne cijene valjaonice s kosim valjanjem i tri valjka koji uzimaju u obzir pozitivne učine za kupca i proizvođača.

Ključne riječi: *vruće valjanje, koso valjanje, šipke, cijevi, teško oblikovljivi materijali*

INTRODUCTION

Growing market demands in terms of both the quality and economy of products compel manufacturers to modernize their existing technologies or implement new ones. Undertakings put a stake on the continual development of technologies by upgrading their machinery or implementing new manufacturing techniques. The high demand for steel and steel products of various types forces manufacturers to adjust their production to the customer's requirements. In order to increase their competitiveness, undertakings cannot limit themselves solely to the external factors governing the sales, but must also perceive possibilities for changes in the internal structure.

The main factors that force the implementation of innovations in the metallurgical sector include:

- market demands concerning new service properties, high quality and low price of steel metallurgical products,
- reduction of investment costs resulting from the reduction of the amount of primary and auxiliary equipment,
- reduction of the labour consumption and costs of the storage of products,
- reduction of manufacturing costs as a result of reducing the number of technological operations and the unit

- consumption of energy and auxiliary materials, and
- increasing the yield and reducing the negative impact on the environment.

One of the prospective directions of the development and improvement of a technological process is its shortening. In the case of plastic working, the elimination of cold plastic working that increases the input costs can be taken into consideration by the application hot rolling on skew rolling mills. For several years, comprehensive theoretical and experimental investigations have been conducted at the Moscow Institute of Steels and Alloys into the possibility of manufacturing small-diameter rods and tubes on the three-roll skew rolling mill [1, 2].

THE CONSTRUCTION OF THE THREE-ROLL SKEW ROLLING MILL [3,4]

A skew mini-rolling mill (Figure 1.) is composed of a rolling stand (1), main motors (2), and the entry (3) and exit (4) parts. The rolling stand include: a housing (5) in the form of two steel plates fixed to the base (6) and joined by rigging screws (7), three cases with working rolls (9) arranged uniformly around the rolling mill axis every 120°, a mechanism for the axial displacement of roll cases along the backing and guiding bars (10) serving for either increasing or decreasing the diameter of rods or tubes being rolled.

A. M. Galkin, A. Rzaśowska - Przala, A. Górniak, Faculty of Materials Processing Technology and Applied Physics Częstochowa University of Technology, Częstochowa, Poland

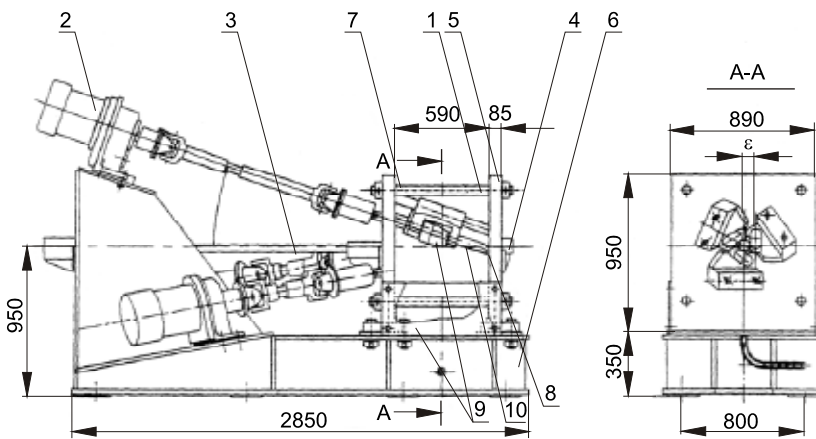

Figure 1. Askew mini-rolling mill [3]
Slika 1. Mini valjaonica za koso valjanje [3]

A BRIEF TECHNICAL SPECIFICATION OF THE 30/1-TYPE ROLLING MILL

- Feedstock diameter < 30 mm;
- Feedstock length 500 - 2000 mm;
- Produced rods and tubes:
 - diameter 10 - 28 mm,
 - length >= 6000 mm;
- Permissible diameter deviations ± 0,1 mm;
- Elongation factor 1,05 - 6,0;
- Yearly efficiency about 1000 - 1500 t;
- Axial rolling speed 40 - 120 mm/s;
- Main drive power 3 × 5 KW;
- Rolling mill mass 1,2 t.

THE METHOD AND RESULTS OF CALCULATION OF THE FAVOURABLE PRICE OF A THREE-ROLL SKEW ROLLING MILL [5]

The price of a new production unit (three-roll skew rolling mill) should be determined not only by the profitability of its manufacture, but also by the viability of its use by the purchaser.

The effectiveness of use of a new production unit is defined by the difference between its market value and the outlays incurred for the production of the unit.

The condition for the profitability of use of a production unit (the profitability of production) is setting a favourable price for both the rolling mill manufacturer and the purchaser of the unit - an optimal price which will bring about profits for both the purchasers and the manufacturers from the implementation of the new technology.

The method of calculation of the price of a new mini-rolling mill, which will be advantageous for both the manufacturer and a potential customer, is shown below. For this purpose, the data from Table 1. have been used.

The following have been calculated in succession:

a) *the rolling mill manufacture profitability index* - as defined by the outlays on its manufacture and the costs of delivery of the unit to the customer, expressed by Equation (1):

$$RPW = \frac{C_w - K_w}{K_p} \times 100\% \tag{1}$$

$$= \frac{22 - 19,5}{25} \times 100\% = 10\%,$$

where:

RPW - the profitability of production of a three-roll skew rolling mill %,

- C_w - rolling mill price + delivery costs,
- K_w - rolling mill manufacturing costs,
- K_p - capital intensity of production of a skew rolling mill;

b) *the profitability of use of a production unit (production profitability index)* - defined by the ratio of the profit to the value of a particular unit, while allowing for the capital outlays (such as investments in buildings and structures, means of transport and other resources necessary for the generation of production), Equation (2):

$$RWU = \frac{Z - (K_{wp} + A_m \times C_w)}{C_w + K_{ch}} \times 100\% \tag{2}$$

$$= \frac{39 - (26 + 0,1 \times 22)}{22 + 9} \times 100\% = 34,8\%,$$

where:

- RWU - the profitability of use of the production unit %,
- Z - profit accrued from the realization of production manufactured on the skew rolling mill,
- K_{wp} - the self-costs of production volume manufactured on the skew rolling mill (without deductions for depreciation),
- A_m - depreciation,
- K_{ch} - capital intensity of production organization (excluding the production unit value);

c) *the calculation of the optimal price of a new production unit.* In order to calculate the favourable price of a new production unit, the right-hand members of Equations (1) and (2) should be equated:

$$C_w^2 - A \times C_w + W = 0, \tag{3}$$

where:

$$A = K_w - K_{ch} - A_m \times K_p = 19,5 - 9 - 0,1 \times 25 = 8,$$

$$W = -K_{ch} \times K_w - Z \times K_p + K_{wp} \times K_p$$

$$= -9 \times 19,5 - 39 \times 25 + 26 \times 25 = -500,5.$$

The optimal price of the production unit is defined by the Equation (4):

$$C_k = \frac{A}{2} + \sqrt{\frac{A^2}{4} - W} = \frac{8}{2} + \sqrt{\frac{8^2}{4} + 500,5} = 26,7, \quad (4)$$

where:

C_k - optimal price of a new production unit.

Table 1. **The economic characteristics of the 30/10 three-roll skew rolling mill**

Tablica 1. **Ekonomске karakteristike 30/10 valjaonice za koso valjanje s trima valjcima**

Lp.	Characteristic	The 30/10-type rolling mill
1	Rolling mill manufacturing costs - K_w [000 \$]	19,5
2	Rolling mill price + delivery costs - C_w [000 \$]	22
3	Capital intensity of production of a skew rolling mill - K_p [000 \$]	25
4	The self - costs of production volume manufactured on the skew rolling mill (without deductions for depreciation) - K_{wp} [000 \$]	26
5	Profit accrued from the realization of production manufactured on the skew rolling mill - Z [000 \$]	39
6	Capital intensity of production organization (excluding the production unit value) - K_{ch} [000 \$]	9
7	Depreciation - A_m [%]	10

Then, the production unit manufacture and use profitability indices have been calculated, while allowing for the optimal price according to Equations (1) and (2):

$$RPW_1 = \frac{C_w - K_w}{K_p} \times 100\%$$

$$= \frac{26,7 - 19,5}{25} \times 100\% = 28,8\%,$$

$$RWU_1 = \frac{Z - (K_{wp} + A_m \times C_w)}{C_w + K_{ch}} \times 100\%$$

$$= \frac{39 - (26 + 0,1 \times 26,7)}{26,7 + 9} \times 100\% = 28,8\%.$$

Table 2. summarizes calculation results for the 30/10 skew rolling mill.

The analysis performed with the use of the profitability indices of rolling mill manufacture and production unit use have confirmed the usefulness of optimal price calculation for both the manufacturers and the new technology users.

The presented method of calculation of the price of a new mini-rolling mill, which is advantageous for both its manufacturer and a potential customer, provides the possibility of determining an optimal price. This price divides the effectiveness and the profits from the implementation of the technology under discussion between the manufacturer and the user.

The profitability indices of the manufacture and use of the production unit, while taking into account the optimal price, are identical and justify the calculation of the optimal price.

Table 2. **The results of calculation for the 30/10 skew rolling mill**
Tablica 2. **Rezultati proračuna za 30/10 valjaonicu za koso valjanje**

Lp.	Characteristic	The 30/10-type rolling mill
1	The price of a new production unit - C_w [000 \$]	22
2	The optimal price of a new production unit - C_k [000 \$]	26,7
3	The rolling mill manufacture profitability index - RPW [%]	10
4	The profitability of use of a production unit (production profitability index) - RWU [%]	34,8
5	The rolling mill manufacture profitability index and the profitability of use of a production unit (production profitability index) with the optimal price of a new production unit - RPW_1, RWU_1 [%]	28,8

(15)

COMPARISON OF THE PROCESS OF BAR AND TUBE HOT ROLLING ON THE SKEW ROLLING MILL WITH OTHER PROCESSES

Bars and tubes of hardly deformable steel can be manufactured by various methods. For the comparative analysis of skew rolling on the 30/10 rolling mill, methods have been selected, which are most often used for their production.

Shape (groove) rolling is the method most frequently used for the production of bars. The rolls are characterized by grooves cut on the roll face, where the band is deformed and receives the desired shape. The grooves of several rolls (two, three or four), comprising in total the perimeter of a given band, except for the roll gap, form a specific pass. During rolling, the band is fed to the pass, where it becomes deformed, while its cross-section takes on the shape of the pass. A desired product is formed as

a result of successive rolling in several passes. In this process, gradual change in the shape and dimensions of the band cross-section is made until a final bar or section is obtained [6].

The manufacture of small-diameter heavy wall tubes is carried out in Poland by the cold rolling method which, for economic reasons, is used for the production of tubes from those steels and alloys that either cannot be deformed by means of drawing, or this process is difficult to accomplish.

The cold tube rolling method is applied for the production of tubes in the outer diameter range from 4 to 250 mm and wall thicknesses from 0,3 to 40 mm. In this method, stock tubes are used, which have been formed in the hot rolling process [7].

In order to present the innovative skew rolling technology offering the capability of hot production of tubes of dimensions of $17 - 30 \times 2,5 - 3$ mm, comparison of strengths and weaknesses of the process of hot tube rolling in skew rolls with the method of cold seamless tube rolling on pilger rolling mills.

Table 3. shows the characteristics of methods, where the advantage is marked with the plus sign, while the drawback with the minus sign.

Table 3. Advantages and drawbacks of selected technological processes [4, 6, 7]

Tablica 3. Prednosti i nedostaci odabranog tehnološkog procesa [4, 6, 7]

Lp.	Feature	Three-Roller Skew Rolling Mill	Groove rolling of bars	Pilger rolling mill for rolling tubes
1	Rolling mill construction	+	-	-
2	Cost of engineering tools	+	-	-
3	Operation and repairs	+	-	-
4	Environmental imp	+	-	-
5	Technological costs of energy	+	-	-
6	Flexibility of technology	+	-	-
7	Accuracy and quality	+	-	+
8	Yield	+	+	+
9	Efficiency	-	+	-

The analysis of gathered information has allowed the following observations to be made:

- the process of hot rolling on skew rolling mills offers a number of advantages compared to the rolling of tubes on the pilger rolling mill and the groove rolling of bars;
- owing to the above-mentioned advantages, the three-roll skew rolling mill is irreplaceable for the production of tubes and bars from alloy steels, corrosion-resisting

steels and heat-resisting steels, as well as alloys on the basis of nickel, titanium, copper, zirconium and other little plastic and hardly deformable materials;

- tubes rolled on the three-roll skew rolling mills can be manufactured either as a finished product or as a blank to be used in a subsequent cold drawing process.

CONCLUSION

The implementation of the new method of manufacturing bars and small-diameter tubes from hardly deformable steels by skew rolling in Polish steel mills would make it possible to broaden the line of these products, which are mostly imported now, and their imports consume a lot of currency resources.

Modernization processes are today, in addition to productivity, an important element of the competitive advantage of metallurgical undertakings. The innovativeness of Poland's tube and bar sectors is low. Therefore, it is of paramount importance to target the development of presently functioning segments at knowledge-based industries capable of sustained and diverse development.

Attempts to restore the tube sector are underway in the Polish steel industry. The data of EuroStrategy Consultants, a company carrying out a sector inquiry into the steel market commissioned by the EU, show that the demand for tubes in Poland reached 850 thousand tonnes in 2005, whereas the forecast foresees more than 900 thousand tonnes for 2006 and nearly 1,3 million tonnes for 2013. The good market situation is stimulated by investments in the infrastructure, and the machine-building, construction and refinery industries.

This situation applies also to stainless steels that are increasingly widely used, not only in undertakings, but also in households.

REFERENCES

- [1] I. N. Potapov, P. I. Polukhin: Tekhnologija vintovoj prokatki, Metallurgy, Moskva 1990, 334.
- [2] S. P. Galkin, V. K. Mikhajlov, V. P. Romanenko, Proizvodstvo Prokata, Moskva (2001) 7, 23.
- [3] S. P. Galkin, H. Dyja, A. M. Galkin, A. Rzašowska: Kinematyczny model płynięcia metalu podczas walcowania skośnego prętów, Hutnik - Wiadomości Hutnicze (2004) 12, 589.
- [4] B. A. Romancjew, S. W. Torszin, W. K. Michajłow: Tjechnologija i oborudowanije dlja rackatki tryb małego diamjetra w trjechwalkowom stanje, Steel. Moskva (1992) 4, 51 - 53.
- [5] A. M. Galkin, S. P. Galkin, A. Rzašowska - Przała, A. Górniak: Rentowność wytworzenia i wykorzystania walcarki skośnej trójwalcowej, Materiały Konferencyjne "Production and Management in the Metallurgical Industry", Szczyrk 2005, 285.
- [6] V. Danchenko, H. Dyja, L. Lesik, L. Mashkin, A. Milenin: Tekhnologija i modelowanie procesów walcowania w wykrojach, Publisher Technical University of Czestochowa, Faculty of Materials Processing Technology and Applied, Czestochowa 2002, 71.
- [7] J. Kozanecki: Wytwarzanie rur bez szwu, Publisher AGH, Cracov 2003, 569.